

X12

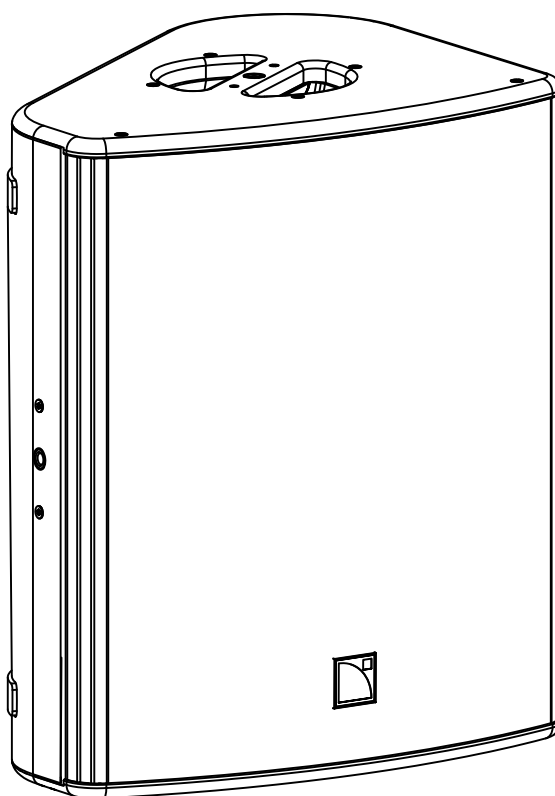

user manual (EN)



Document reference: X12 user manual (EN) version 5.0

Distribution date: June 15, 2018

© 2018 L-Acoustics. All rights reserved.

No part of this publication may be reproduced or transmitted in any form or by any means without the express written consent of the publisher.

Contents

Safety.....	5
Instructions.....	5
Symbols.....	5
Welcome.....	6
System components.....	7
Loudspeaker cables.....	8
Technical description.....	9
Low-latency preset.....	9
Directivity.....	9
Monitor angles.....	10
Loudspeaker configurations.....	11
X12 point source.....	11
X12 point source with LF.....	12
X12 with SB15m.....	12
X12 with SB18.....	13
X12 stage monitor.....	14
X12 stage monitor with LF.....	15
X12 with SB15m.....	15
X12 with SB18.....	16
Loudspeaker connection.....	17
Connectors.....	17
Connection to LA4X.....	18
Connection to LA8.....	19
Connection to LA12X.....	19
Preset description.....	21
Recommendation for speaker cables.....	22
Maintenance.....	23
Disassembly and Reassembly procedures.....	23
D/R - Grill.....	24
D/R - Coaxial loudspeaker.....	25
D/R - HF diaphragm.....	26
Acoustical check.....	27

Specifications.....	31
X12 specifications.....	31
SB15m specifications.....	33
SB18 specifications.....	35



Safety

Instructions

- 
Inspect the system before any deployment.
 Perform safety related checks and inspections before any deployment.
- Perform preventive maintenance at least once a year.**
 Refer to the preventive maintenance section for a list of actions and their periodicity.
 Insufficient upkeep of the product can void the warranty.
- If any safety issue is detected during inspection, do not use the product before performing corrective maintenance.**
- 
Never incorporate equipment or accessories not approved by L-Acoustics.
- 
Read all the related PRODUCT INFORMATION documents shipped with the products before exploiting the system.
- 
Do not store the product on an unstable cart, stand, tripod, bracket, or table.
- 
Beware of sound levels.
 Do not stay within close proximity of loudspeakers in operation.
 Loudspeaker systems are capable of producing very high sound pressure levels (SPL) which can instantaneously lead to permanent hearing damage to performers, production crew and audience members. Hearing damage can also occur at moderate level with prolonged exposure to sound.
 Check the applicable laws and regulations relating to maximum sound levels and exposure times.
- 
Intended use
 This system is intended for use by trained personnel for professional applications.
- 
Read the RIGGING MANUAL before installing the system.
 Use the rigging accessories described in the rigging manual and follow the associated procedures.
- Read the maintenance section of this document before servicing the product.**
- 
Do not expose the product to extreme conditions.
 Do not expose the product to rain or sea spray.
 Do not expose the product to moisture (mist, steam, humidity, condensation...) or excessive heat (direct sun, radiator...) for a long period of time.
- 
Contact L-Acoustics for advanced maintenance.
 Any unauthorized maintenance operation will void the product warranty.

Symbols

The following symbols are used in this document:

- 
 This symbol indicates a potential risk of harm to an individual or damage to the product.
 It can also notify the user about instructions that must be strictly followed to ensure safe installation or operation of the product.
- 
 This symbol notifies the user about instructions that must be strictly followed to ensure proper installation or operation of the product.
- 
 This symbol notifies the user about complementary information or optional instructions.

Welcome

Thank you for purchasing the L-Acoustics X12.

This document contains essential information on using the system properly.

As part of a continuous evolution of techniques and standards, L-Acoustics reserves the right to change the specifications of its products and the content of its document without prior notice. Please check www.l-acoustics.com on a regular basis to download the latest document and software updates.

X12 multi-purpose enclosure

The X12 is a multipurpose coaxial system perfectly suited to all short throw sound reinforcement applications. The enclosure features a 3" diaphragm compression driver coaxially loaded by a 12" low frequency transducer in a bass-reflex cabinet. The L-Vents laminar vented ports reduce turbulence and port noise at high levels to increase LF efficiency.

The X12 operates from 59 Hz to 20 kHz. The coaxial transducer arrangement and its ellipsoid acoustic design produce a 90° x 60° directivity pattern with a smooth tonal response free of secondary lobes over the entire frequency range.

The internal passive crossover network uses custom filters. The L-Acoustics amplified controllers L-Drive parameters ensure the linearization and protection of the transducers.

With a cabinet combining the properties of birch and beech plywood, X12 weighs 20 kg and its elegance makes for an easy integration in any situation. Ergonomic handles provide a solid grip and efficient handling. An optional white or RAL color program means that it can melt into any architecture. The X12 provides a stage monitoring angle setting of 35° with regard to vertical or 55° thanks to its built-in risers.

The ellipsoid directivity of 90° x 60° gives optimized coverage for FOH and fill applications, distributed systems, stage monitoring and more. The compact footprint allows for discreet integration, preserving sightlines. The passive design reduces the need for amplified controller.

The X12 can be pole-mounted using the integrated socket. Other deployments such as wall-mounted, ceiling-mounted or flown are quick and easy, with a complete range of rigging accessories that offer multiple set-up options and various orientations.

System components

Loudspeaker enclosures

X12	2-way passive coaxial enclosure: 12" LF + 3" HF diaphragm
SB15m	High power compact subwoofer : 1 x 15"
SB18	High power compact subwoofer: 1 x 18"

SB18 / SB18i / SB18m

In this document, the SB18 term and illustrations refer equally to SB18, SB18i or SB18m.

Powering and driving system

LA4X / LA8 / LA12X	Amplified controller with DSP, preset library and networking capabilities
LA-RAK	Touring rack containing three LA8 and power, audio and network distribution
LA-RAK II	Touring rack containing three LA12X, LA-POWER II for power distribution and LA-PANEL II for audio and network distribution



Refer to the LA4X / LA8 / LA12X user manual for operating instructions.

Loudspeaker cables

SP cables	4-point speakON loudspeaker cables (4 mm ² gauge) SP cables come in four sizes: SP.7 (0.7 m/2.3 ft), SP5 (5 m/16.4 ft), SP10 (10 m/32.8 ft) and SP25 (25 m/82 ft)
SP-Y1	breakout cable for two passive enclosures (2.5 mm ² gauge) provided with a CC4FP adapter 4-point speakON to 2 x 2-point speakON
DO	8-point PA-COM loudspeaker cables (4 mm ² gauge) DO cables come in three sizes: DO.7 (0.7 m/2.3 ft), DO10 (10 m/32.8 ft) and DO25 (25 m/82 ft)
DOSUB-LA8	breakout cable for four passive enclosures (4 mm ² gauge) 8-point PA-COM to 4 x 2-point speakON



Information about the connection of the enclosures to the LA amplified controllers is given in this document.

Refer to the LA4X / LA8 / LA12X user manual for detailed instructions about the whole cabling scheme, including modulation cables and network.

Rigging elements



Rigging elements or procedures are not presented in this document.
Refer to the X12 rigging manual.

Software applications

Soundvision	3D acoustical and mechanical modeling software
LA Network Manager	Software for remote control and monitoring of amplified controllers



Refer to the **Soundvision** help.



Refer to the **LA Network Manager** help.

Loudspeaker cables

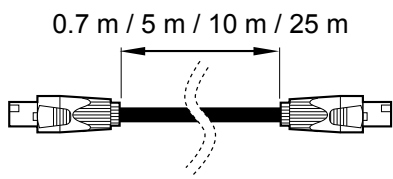

SP.7 / SP5 / SP10 / SP25

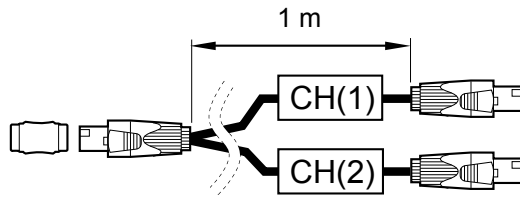

SP-Y1

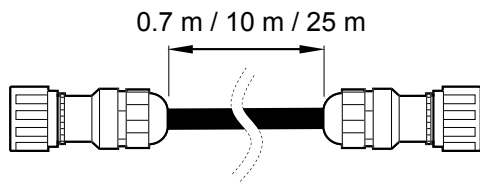

DO.7 / DO10 / DO25

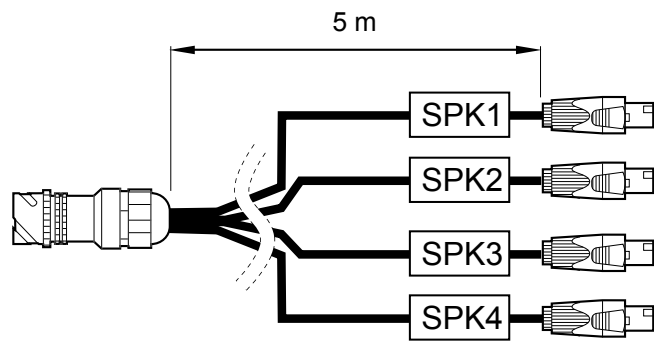

DOSUB-LA8

Technical description

Low-latency preset

A low-latency preset is available for the X12 enclosure used as a monitor ([X12_MO]). It reduces latency from 3.84 ms down to 1.18 ms (LA8) and 0.84 ms (LA4X / LA12X). If the monitor is combined with a subwoofer, a custom preset must be used.

Directivity

X12 features a coaxial transducer arrangement coupled with an ellipsoid waveguide that generates an H/V directivity pattern of 60° x 90°.

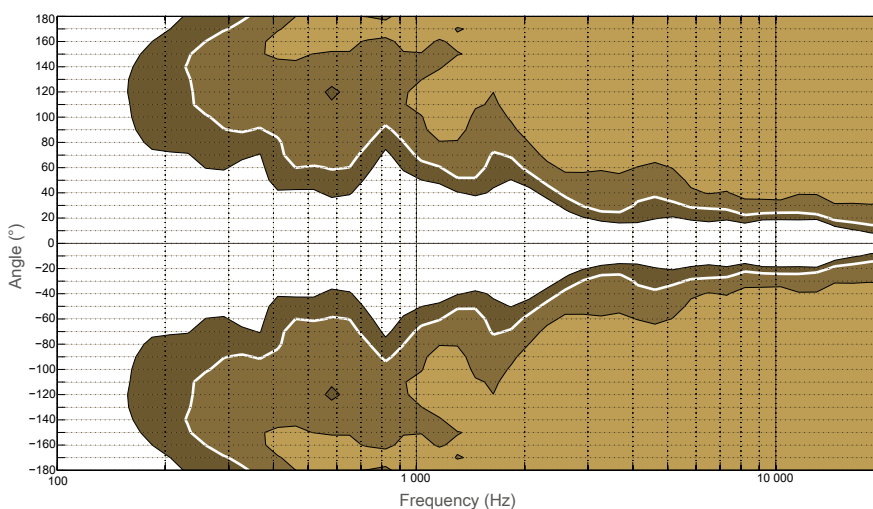
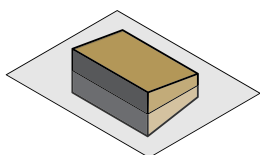
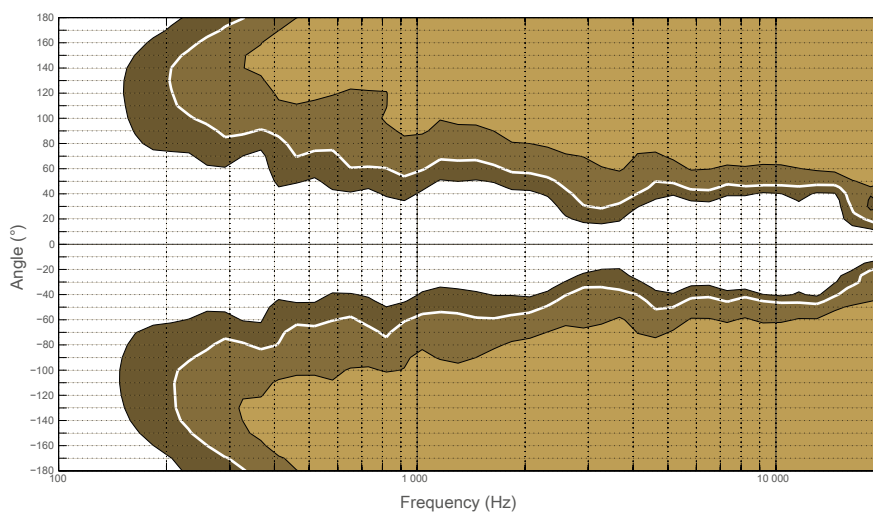
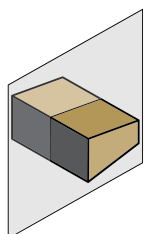

Dispersion angle diagram of a single X12 using lines of equal sound pressure at -3 dB, -6 dB, -12 dB.

Monitor angles

X12 features risers that allow to change the monitor angle from 35° to 55°.

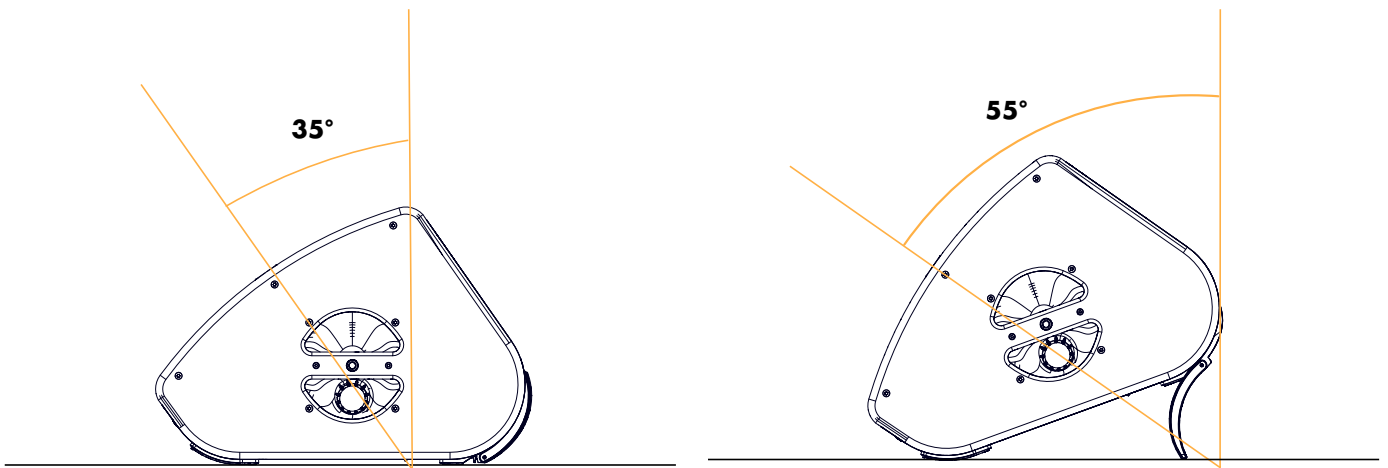

Loudspeaker configurations

X12 point source

Deployed as a standalone point source, an X12 system operates over the nominal bandwidth of the X12 enclosure.

The [X12] preset allows for a reference frequency response in short throw applications.

The X12 enclosure is driven by the LA4X / LA8 / LA12X amplified controllers.

Standalone X12

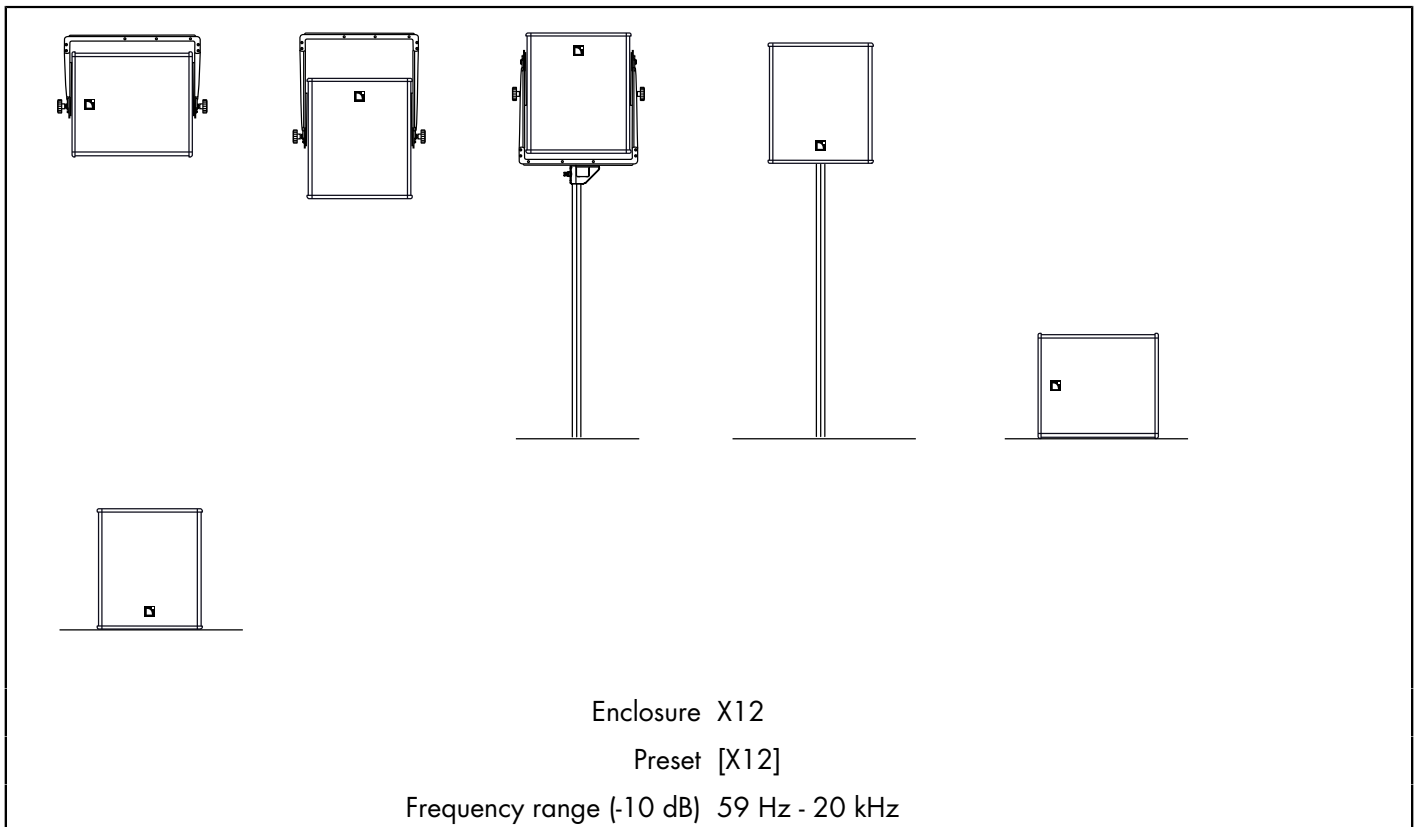

X12 point source with LF

Deployed as a point source with SB15m or SB18 subwoofers, an X12 system operates with augmented LF resources.

The [X12] preset allows for a reference frequency response in short throw applications.

The [SB15_100] and [SB18_100] presets provide the SB15m and SB18 with an upper frequency limit at 100 Hz for an optimal frequency coupling with the X12.

The X12, SB15m and SB18 enclosures are driven by the LA4X / LA8 / LA12X amplified controllers.

X12 with SB15m

With SB15m, the X12 system contour is reinforced by 8 dB at 100 Hz and the system bandwidth is extended down to 40 Hz.

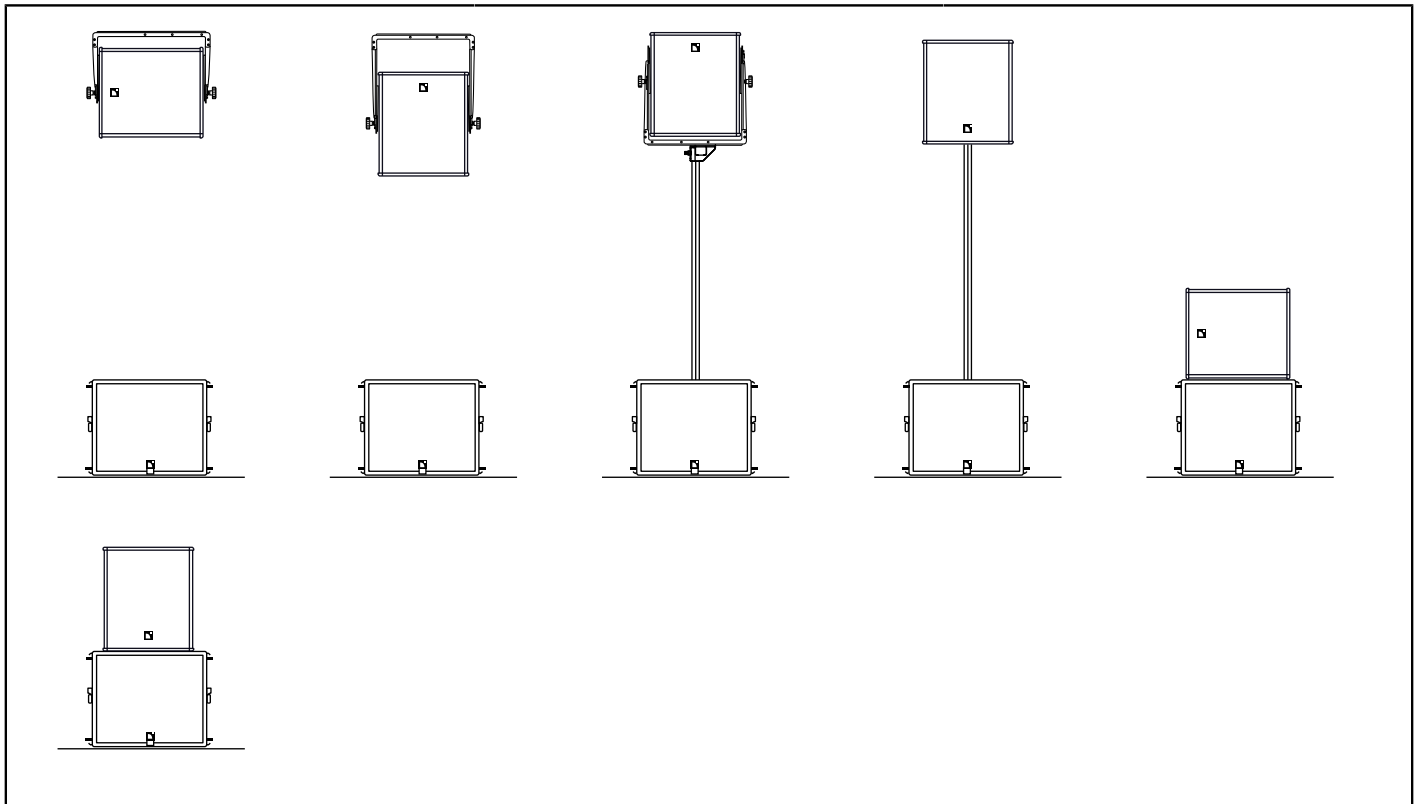

Enclosure	X12	SB15m
Preset	[X12]	[SB15_100]
Frequency range (-10 dB)	40 Hz - 20 kHz	
Enclosure ratio	1 X12 : 1 SB15m	



Delay values

Do not forget to add the pre-alignment and geometric delays depending on the configuration.

Pre-alignment delays

[X12] + [SB15_100]	X12 = 0 ms	SB15m = 2.8 ms
--------------------	------------	----------------

X12 with SB18

With SB18, the X12 system contour is reinforced by 5 dB at 100 Hz, and the system bandwidth is extended down to 32 Hz.

Enclosure	X12	SB18
Preset	[X12]	[SB18_100]
Frequency range (-10 dB)	32 Hz - 20 kHz	
Enclosure ratio	1 X12 : 1 SB18	



Delay values

Do not forget to add the pre-alignment and geometric delays depending on the configuration.

Pre-alignment delays

[X12] + [SB18_100]	X12 = 0 ms	SB18 = 0 ms
--------------------	------------	-------------

X12 stage monitor

Deployed as a stage monitor, an X12 system operates over the nominal bandwidth of the X12 enclosure.

The [X12_MO] preset allows for a reference frequency response in stage monitoring applications.

The X12 enclosure is driven by LA4X / LA8 / LA12X.

Standalone X12

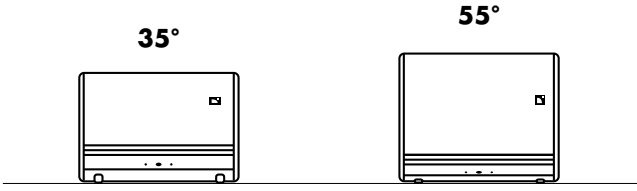
Enclosure X12
Preset [X12_MO]
Frequency range (-10 dB) 57 Hz - 20 kHz

Paired X12 monitors with LFC

The Low Frequency Contour (LFC) tool implemented in LA Network Manager can compensate for coupling effects between closely operating monitors. LFC allows to adjust the frequency response curve to obtain the desired low frequency contour.

For paired X12 monitors, enter the following parameters to obtain the reference response curve of a single enclosure:

	LF Contour	
FREQ/RATIO	180	N/A
GAIN	-3.0	

For more information about LFC, refer to the **LA Network Manager Help** (section: Group Control Panel) and to the **Array Morphing** white paper, available on www.l-acoustics.com (Download Center).

X12 stage monitor with LF

Deployed as a stage monitor with SB15m or SB18 subwoofers, an X12 system operates with augmented LF resources. The [X12_MO] preset allows for a reference frequency response in stage monitoring applications.

The [SB15_100] and [SB18_100] presets provide the SB15m and SB18 with an upper frequency limit at 100 Hz for an optimal frequency coupling with the X12.

The X12, SB15m and SB18 enclosures are driven by the LA4X / LA8 / LA12X amplified controllers.

X12 with SB15m

With SB15m, the X12 system contour is reinforced by 8 dB at 100 Hz and the system bandwidth is extended down to 40 Hz.

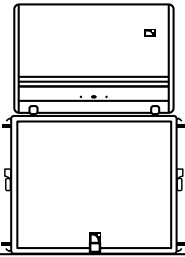
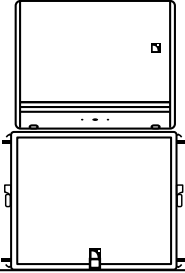
	35°	55°
		
Enclosure	X12	
Preset	[X12_MO]	
Frequency range (-10 dB)	40 Hz - 20 kHz	
Enclosure ratio	1 X12 : 1 SB15m	

! Delay values

Do not forget to add the pre-alignment and geometric delays depending on the configuration.

Pre-alignment delays

[X12_MO] + [SB15_100]	X12 = 0 ms	SB15m = 2.8 ms
-----------------------	------------	----------------

! [xx_MO] presets for the X series use the amplified controller low latency operating mode. When used along with subwoofers, it is recommended to use the subwoofers in low latency operating mode. To achieve this, create custom presets combining low latency channel sets and subwoofer channel sets.

If the subwoofers are driven from a dedicated amplified controller using a subwoofer factory preset, they are operated in normal latency mode. Therefore, an additional delay should be set to the [xx_MO] low latency channels to align them: 2.66 ms on LA8 or 3.00 ms on LA4X and LA12X.

X12 with SB18

With SB18, the X12 system contour is reinforced by 5 dB at 100 Hz, and the system bandwidth is extended down to 32 Hz.

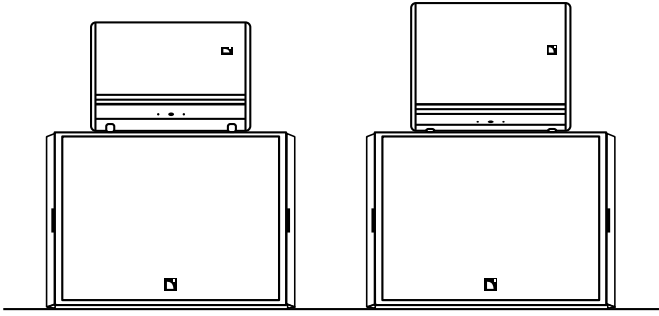
		
Enclosure	X12	SB18
Preset	[X12_MO]	[SB18_100]
Frequency range (-10 dB)	32 Hz - 20 kHz	
Enclosure ratio	1 X12 : 1 SB18	

! Delay values

Do not forget to add the pre-alignment and geometric delays depending on the configuration.

Pre-alignment delays

[X12_MO] + [SB18_100]	X12 = 0 ms	SB18 = 0 ms
-----------------------	------------	-------------

! [xx_MO] presets for the X series use the amplified controller low latency operating mode. When used along with subwoofers, it is recommended to use the subwoofers in low latency operating mode. To achieve this, create custom presets combining low latency channel sets and subwoofer channel sets.

If the subwoofers are driven from a dedicated amplified controller using a subwoofer factory preset, they are operated in normal latency mode. Therefore, an additional delay should be set to the [xx_MO] low latency channels to align them: 2.66 ms on LA8 or 3.00 ms on LA4X and LA12X.

Loudspeaker connection

Connectors

X12 is equipped with two 4-point speakON connectors.

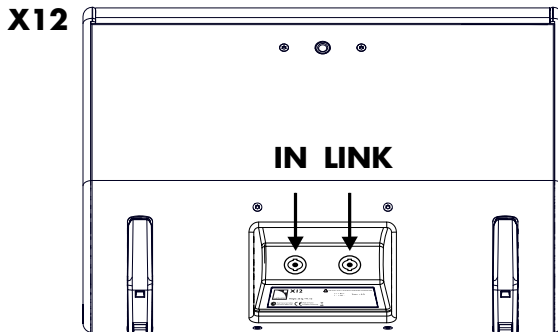

Internal pinout for L-Acoustics 2-way passive enclosures

speakON points	1 +	1 -	2 +	2 -
Transducer connectors	+	-	Not linked	Not linked

SB15m is equipped with two 4-point speakON connectors.

SB18 is equipped with two 4-point speakON connectors.

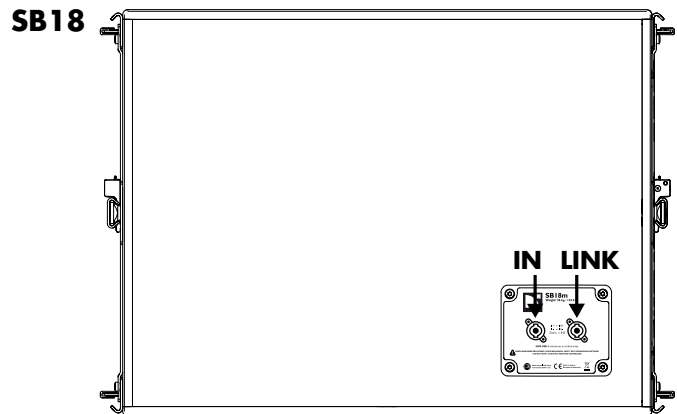
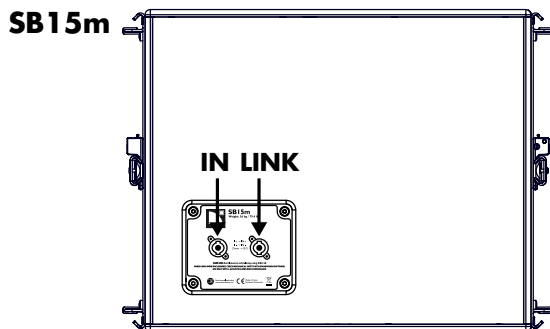

Internal pinout for L-Acoustics subwoofers

speakON points	1 +	1 -	2 +	2 -
Transducer connectors	LF +	LF -	Not linked	Not linked

Connection to LA4X

Maximum number of enclosures per LA4X

enclosure	max enclosures in parallel	max enclosures per controller
X12	1	4
SB15m	1	4
SB18	1	4

Impedance load

X12 SB15m SB18

1 enclosure: 8 Ω

Connecting 2-way passive enclosures or subwoofers

SP on speakON output

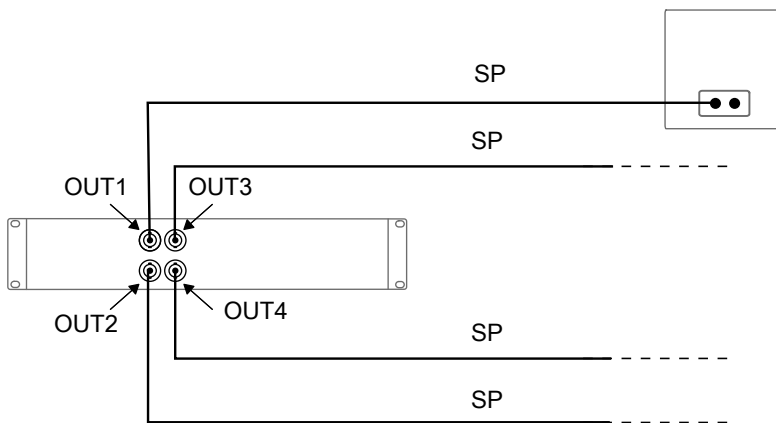

SP and SP-Y1 on speakON output

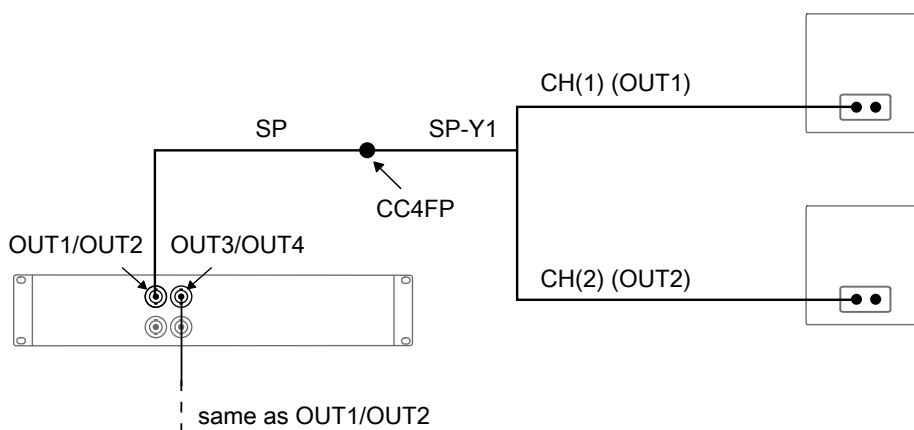

Connection to LA8

Maximum number of enclosures per LA8

enclosure	max enclosures in parallel	max enclosures per controller
X12	2	8
SB15m	2	6
SB18	2	8

! Make sure the total number of connected enclosures does not exceed the maximum number of enclosures per controller.

LA8 can drive up to two SB15m per output, but no more than six per controller.

Impedance load

X12 SB15m SB18

1 enclosure: 8 Ω

2 enclosures in parallel: 4 Ω

Connection to LA12X

Maximum number of enclosures per LA12X

enclosure	max enclosures in parallel	max enclosures per controller
X12	3	12
SB15m	3	12
SB18	3	12

Impedance load

X12 SB15m SB18

1 enclosure: 8 Ω

2 enclosures in parallel: 4 Ω

3 enclosures in parallel: 2.7 Ω

Connecting 2-way passive enclosures or subwoofers

SP and SP-Y1 on speakON output

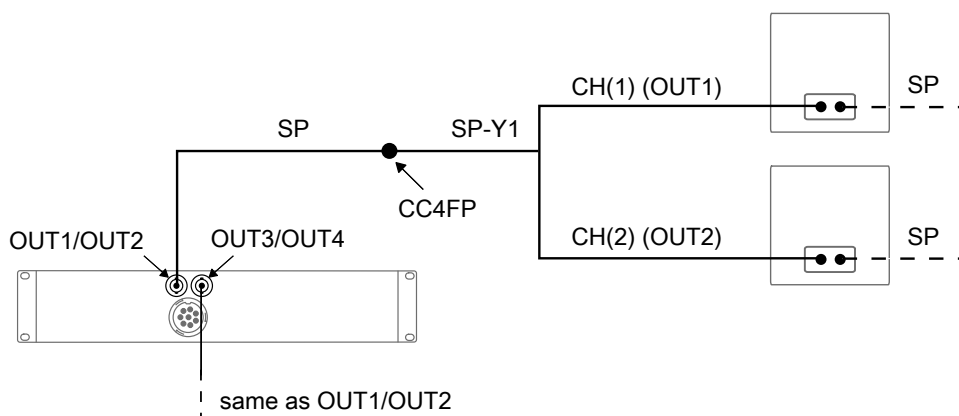

DO and DOSUB-LA8 on CA-COM output

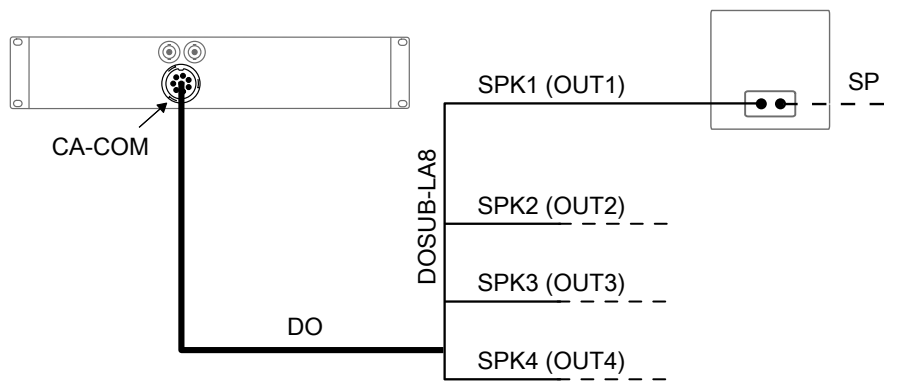

Preset description

[X12_MO]

outputs	channels	routing	gain	delay	polarity	mute
OUT 1	PA	IN A	0 dB	0 ms	+	ON
OUT 2	PA	IN A	0 dB	0 ms	+	ON
OUT 3	PA	IN B	0 dB	0 ms	+	ON
OUT 4	PA	IN B	0 dB	0 ms	+	ON

[X12]

outputs	channels	routing	gain	delay	polarity	mute
OUT 1	PA	IN A	0 dB	0 ms	+	ON
OUT 2	PA	IN A	0 dB	0 ms	+	ON
OUT 3	PA	IN A	0 dB	0 ms	+	ON
OUT 4	PA	IN A	0 dB	0 ms	+	ON

[SB18_100] [SB15_100]

outputs	channels	routing	gain	delay	polarity	mute
OUT 1	SB	IN A	0 dB	0 ms	+	ON
OUT 2	SB	IN A	0 dB	0 ms	+	ON
OUT 3	SB	IN A	0 dB	0 ms	+	ON
OUT 4	SB	IN A	0 dB	0 ms	+	ON

[SB18_100_C] [SB15_100_C]

loudspeaker elements	outputs	channels	routing	gain	delay	polarity	mute
SR	OUT 1	SR	IN A	0 dB	0 ms	+	ON
SB	OUT 2	SB					ON
SB	OUT 3	SB					ON
SB	OUT 4	SB					ON

Recommendation for speaker cables

Follow the recommended maximum length for loudspeaker cables to ensure minimal SPL attenuation.



Cable quality and resistance

Only use high-quality fully insulated speaker cables made of stranded copper wire.

Use cables with a gauge offering low resistance per unit length and keep the cables as short as possible.

The table below provides the recommended maximum length for loudspeaker cables depending on the cable gauge and on the impedance load connected to the amplifier.

cable gauge			recommended maximum length					
			8 Ω load		4 Ω load		2.7 Ω load	
mm ²	SWG	AWG	m	ft	m	ft	m	ft
2.5	15	13	30	100	15	50	10	33
4	13	11	50	160	25	80	17	53
6	11	9	74	240	37	120	25	80

For your installation projects, you can use the more detailed L-ACOUSTICS calculation tool to evaluate cable length and gauge based on the type and number of enclosures connected. The calculation tool is available on our website:

<http://www.l-acoustics.com/installation-outils-de-calcul-137.html>

Maintenance

Disassembly and Reassembly procedures

In order to operate, follow the order outlined here. Each assembly refers to the corresponding D/R procedure and the necessary repair kit.

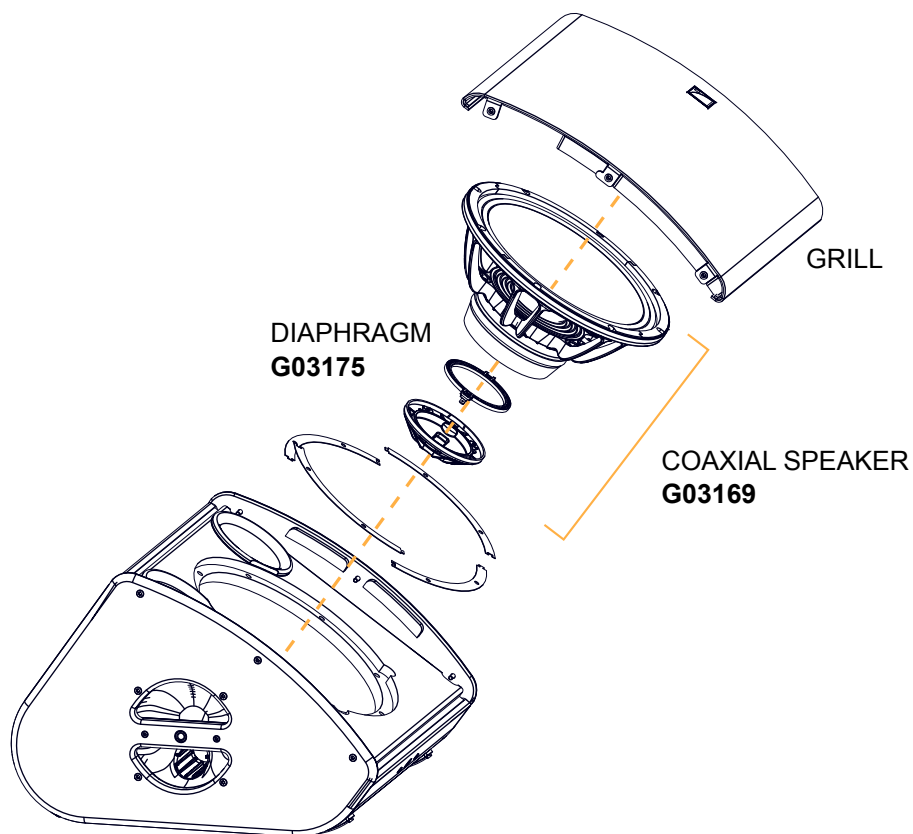

D/R - Grill

Tools

- torque screwdriver
- T25 Torx bit

Repair kit

G03169 - KR coaxial speaker X12 or

G03175 - KR diaphragm X12





x6

S100033

M5x25 Torx

Exploded view

 For safety reasons, always use the new screws and spare parts provided in the KR.
If no new screws are available, use blue threadlocker.

 Gradually tighten the screws following a star pattern.

Position the logo on the right side.

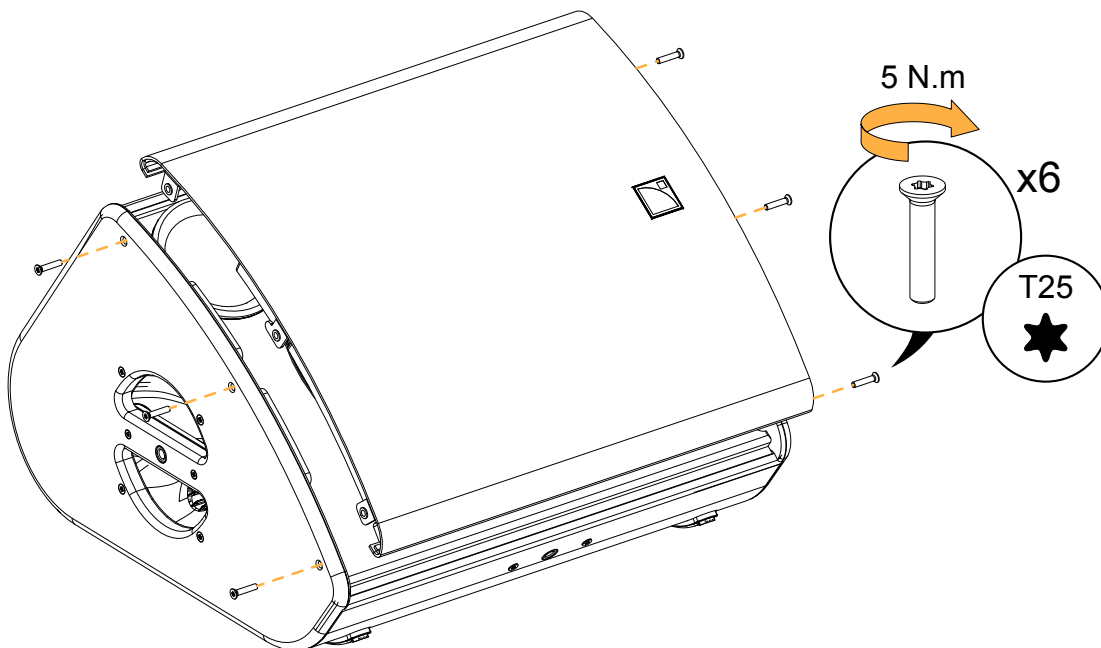

D/R - Coaxial loudspeaker

Tools

- torque screwdriver
- 5 mm hex bit

Repair kit

G03169*

KR coaxial speaker X12

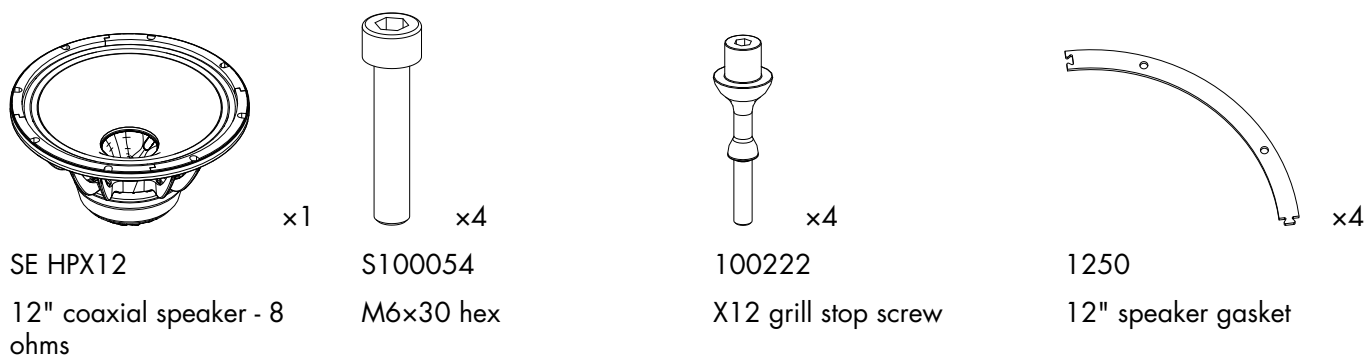

* The screws and gaskets are also available in G03175 - KR diaphragm X12 .

Prerequisite

Grill disassembled.

See [Grill](#) (p.24).

Exploded view

! For safety reasons, always use the new screws and spare parts provided in the KR.

! Gradually tighten the screws following a star pattern.

i If the speaker gasket is damaged, remove and replace it.

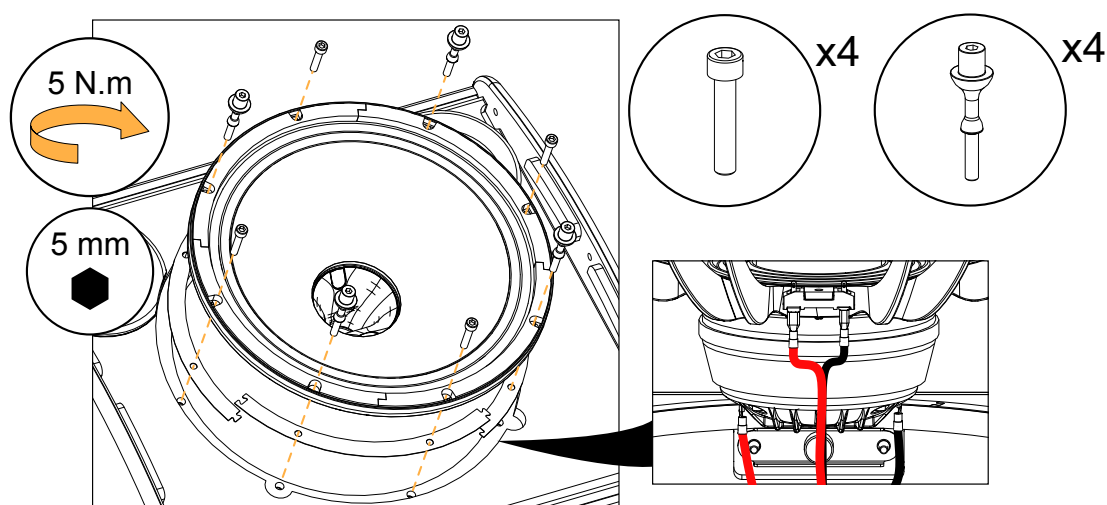

What to do next

Perform the [Acoustical check](#) (p.27) procedures.

D/R - HF diaphragm

Tools

- torque screwdriver
- 3 mm hex wrench
- 3 mm hex bit
- blower

Consumables

- double face adhesive tape

Repair kit

G03175

KR diaphragm X12

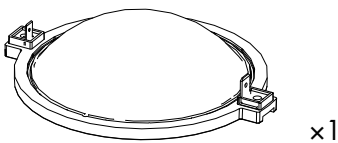

17581

diaphragm assembly (with 2 shims)

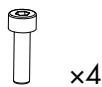

S100082

M4x14 hex

Prerequisite

Grill disassembled.

Coaxial speaker removed.

The speaker is placed on a flat surface in a dust-free environment.

See [Grill](#) (p.24).

See [Coaxial loudspeaker](#) (p.25).

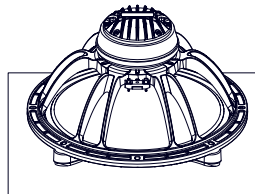

Disassembly

Procedure

1. Remove the four screws securing the cover.
Use the 3 mm hex bit.
2. Remove the cover.
3. Carefully remove the diaphragm.
4. If there are shims on the dome, carefully remove them.
Take note of how many and what kind of shims are present.

Reassembly

About this task

! For safety reasons, always use the new screws and spare parts provided in the KR.

Procedure

1. Clean the dome and the air gap.
Use a blower or double face adhesive tape to remove any particle.
- !** Make sure the air gap is perfectly clean before moving to the next step.
2. Place the same kind and number of shims that were initially present.
3. Carefully place the diaphragm.
4. Position the diaphragm using the LF cable connectors as reference points.
Place the small HF connector on the same side as the small LF connector.
5. Secure the cover to the speaker using four S100082 screws.
 - a) Gradually secure each screw manually with the 3 mm hex wrench.

Follow a cross scheme.

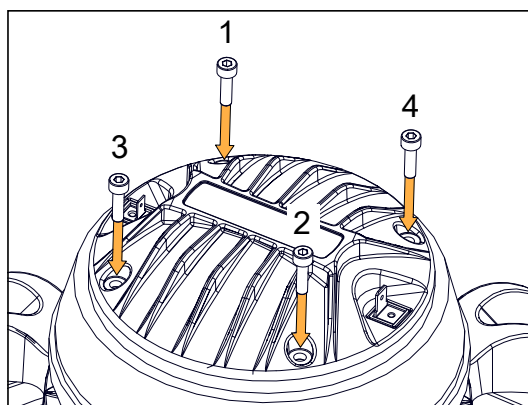

- b) Tighten the screws in the same order with the electric screwdriver.
Use the 3 mm hex bit. Set the torque to 3.5 Nm.

What to do next

Perform the [Acoustical check](#) (p.27) procedures.

Acoustical check

Enclosure check

! **This feature is available on:**
LA4X
LA12X

ENCLOSURE CHECK measures impedance at the reference frequencies for the connected loudspeaker family. The measured impedance is compared to the expected range allowing for fast detection of loudspeakers presenting circuit continuity issues.

i The results can be used for preliminary diagnosis but cannot replace a comprehensive quality control.

Prerequisite

! **ENCLOSURE CHECK measurements can only be reliable if the following requirements are met:**

Environment and temperature:

- Ambient temperature must be comprised between 0 °C / 32 °F and 40 °C / 104 °F. Ideal temperature is 20 °C / 68 °F.
- Enclosures must be at room temperature. If warm from a recent high level use or recently moved from a cold environment, let the loudspeakers reach room temperature before starting.

Enclosures:

- Enclosures must be included in the embedded factory preset library.
- Enclosures must be in nominal operating conditions:
 - Remove covers or dollies obstructing the loudspeakers or the vents.
 - Check for obvious physical damage or air leak: visually inspect the grill, gasket, cabinet, and connector plate for loose, missing or damaged parts.

Connection:

- Use only 10 m / 30 ft 4 mm² / AWG 11 speaker cables.
- Do not connect enclosures in parallel.

Amplified controllers:

- LA4X must run at least firmware version 1.1.0.
- LA4X load sensors must be calibrated. Refer to the technical bulletin for more information.
- LA4X must warm up for at least 10 minutes after power up. Do not power off, reboot or switch to standby mode to avoid resetting the countdown.
- Load a preset corresponding to the connected loudspeaker's family. Presets from the user memories may be used on condition they are made of presets supported in the embedded factory preset library.

Procedure

1. Power up the amplified controller. Let LA4X warm up for at least 10 minutes.
2. Connect the loudspeaker enclosures to the amplified controller.
3. Load a preset from or built from the embedded library corresponding to the connected loudspeaker family.
4. On the amplified controller, use the encoder wheel to select **MONITORING & INFO**. Press the OK key or the encoder wheel to validate.
5. Use the encoder wheel to select **ENCLOSURE CHECK**.

**Beware of sound levels.**

Although the sound pressure levels generated for the ENCLOSURE CHECK are moderate, do not stay within close proximity of the loudspeakers and consider wearing ear protection.

6. Press the OK key or the encoder wheel to launch the ENCLOSURE CHECK.

The amplified controller generates short sinusoidal signals simultaneously for each connected output.

The amplified controller displays the results for each output.

7. Depending on the displayed results, follow the instructions in the table.

result	interpretation	instructions
OK	measured impedance is within expected range	enclosure is in working order electrically
?	unsupported preset family	only supported enclosures should be tested
NC	Not Connected	if cables are connected: a. inspect the cables and connections b. go to step 8 (p.28)
NOK	measured impedance is not within expected range	a. check that all the prerequisites are met, in particular that the loaded preset corresponds to the connected speaker's family b. inspect the cables and connections c. go to step 8 (p.28)
UNDEF	measured impedance is undefined	

8. Under NC, NOK and UNDEF results, press and hold the corresponding OUT key.

The amplified controller displays:

- the tested frequencies,
- information on the measured impedance:
 - OPEN for open circuit (found in NC results),
 - SHORT for short circuit (found in NOK results), or
 - a percentage of variation from the expected range (found in NOK and UNDEF results)
- the number of operational transducers out of the total



Low variations from the expected range are acceptable: displayed percentage can be different from 0 and all transducers considered operational.

Listening test

Procedure

1. Load the preset on an LA4X / LA8 / LA12X amplified controller.
2. Connect a sinus generator to the amplified controller.



Risk of hearing damage

Set a low sound level to start and use ear protection to adjust before testing.

3. Scan the bandwidth focusing on the usable range.
The sound should remain pure and free of unwanted noise.

Troubleshooting for HF speakers

One or more HF loudspeaker produces high-frequency harmonic distortions, strange vibrations or weak sound.

Possible causes

- There are foreign particles on the air gap.
- The screws used for reassembly are too loose.
- The diaphragm is damaged.
- The number of shims is wrong.

Procedure

1. Perform the diaphragm disassembly procedure.
2. Visually inspect the diaphragm and the voice coil.
If any damage is visible, replace the diaphragm.
3. Clean the air gap thoroughly.
4. Perform the reassembly procedure.
Pay close attention to the number of shims and the position of the diaphragm.
Apply the recommended torque.
5. Repeat the listening test.



If a buzzing sound is still audible, it might be necessary to add an extra shim on the air gap.

Troubleshooting for LF speakers

One or more LF loudspeaker produces distorted, buzzing, rubbing, clicking, muffled or weak sound.

Possible causes

- The screws used for reassembly are too loose.
- There is an air leak in the gasket.
- There is dust on the cone.
- The cone is damaged.
- The surround is torn or delaminated.
- The voice coil and/or the spider is damaged.

Procedure

1. Perform the loudspeaker disassembly procedure.
2. Visually inspect the loudspeaker and the cables.
If any damage is visible, replace the loudspeaker.
3. Carefully clean the loudspeaker with a dry cloth.
4. Perform the reassembly procedure.
Replace the loudspeaker gasket and the screws.
Apply the recommended torque.
5. Repeat the listening test.
If the problem persists, replace the loudspeaker.

Specifications

X12 specifications

Description	2-way passive coaxial enclosure: 12" LF + 3" HF diaphragm, amplified by LA4X / LA8 / LA12X
Usable bandwidth (-10 dB)	59 Hz - 20 kHz ([X12])
Maximum SPL¹	136 dB ([X12])
Nominal directivity	vertical: symmetric horizontal: symmetric
Monitoring angle	without risers: 35° with risers: 55°
Transducers	LF: 1 × 12" cone driver HF: 1 × 3" diaphragm compression driver, neodymium
Acoustical load	bass-reflex, L-Vents, ellipsoidal waveguide
Nominal impedance	8 Ω
Connectors	IN: 1 × 4-point speakON LINK: 1 × 4-point speakON
Rigging and handling	2 × handles DIN580-compatible M8 threaded insert 4 M10 threaded inserts 1 × 35 mm pole socket
Weight (net)	20 kg / 44.1 lb
Cabinet	first grade Baltic beech and birch plywood
Front	steel with anti-corrosion coating acoustically neutral 3D fabric
Finish	dark grey brown Pantone 426C pure white RAL 9010 custom RAL code on special order
IP	IP43

¹ Peak level measured at 1 m under free field conditions using pink noise with crest factor 4 (preset specified in brackets).

X12 dimensions

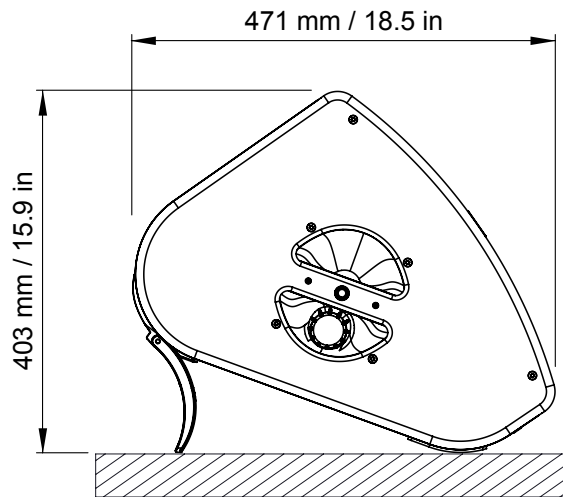
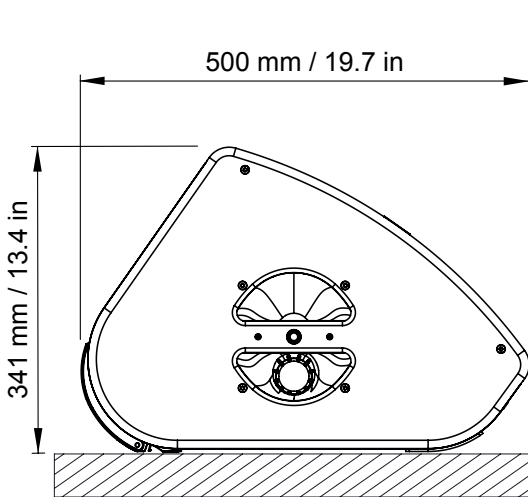
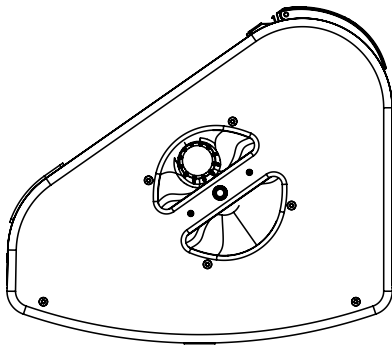
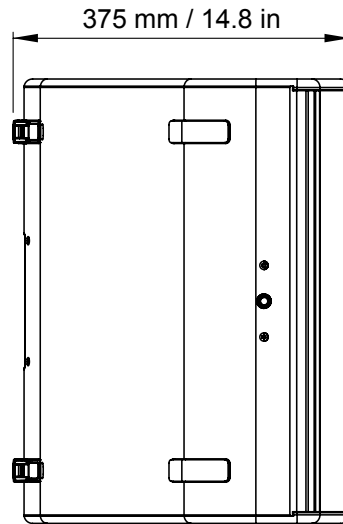
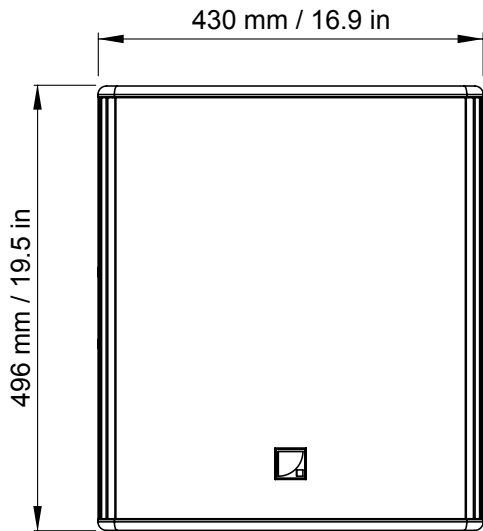

SB15m specifications

Description	High power compact subwoofer : 1 x 15" , amplified by LA4X / LA8 / LA12X
Low frequency limit	40 Hz ([SB15_100])
Maximum SPL¹	137 dB ([SB15_100])
Directivity	standard or cardioid
Transducers	1 x 15"
Acoustical load	bass-reflex enclosure, L-Vents
Nominal impedance	8 Ω
Connectors	IN: 4-point speakON LINK: 4-point speakON
Rigging and handling	2 handles 2 coupling bars and 2 locking tabs 1 x 35 mm pole socket
Weight (net)	36 kg / 79.4 lb
Cabinet	first grade Baltic birch plywood
Front	steel grill with anti-corrosion coating acoustically neutral 3D fabric
Rigging components	high grade steel with anti-corrosion coating
Finish	dark grey brown Pantone 426C pure white RAL 9010 custom RAL code on special order

¹ Peak level at 1 m under half space conditions using pink noise with crest factor 4 (preset specified in brackets).

SB15m dimensions

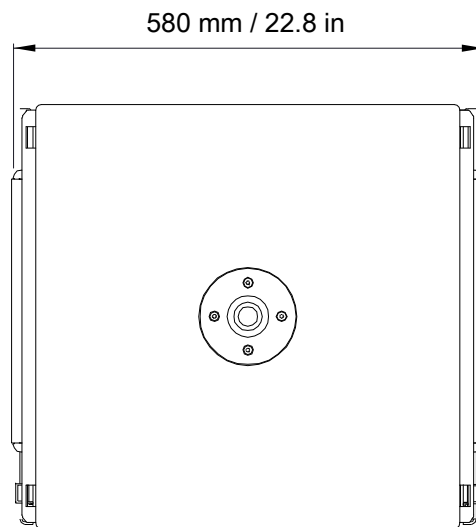
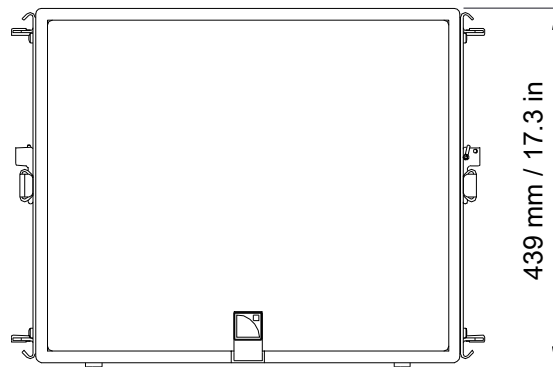
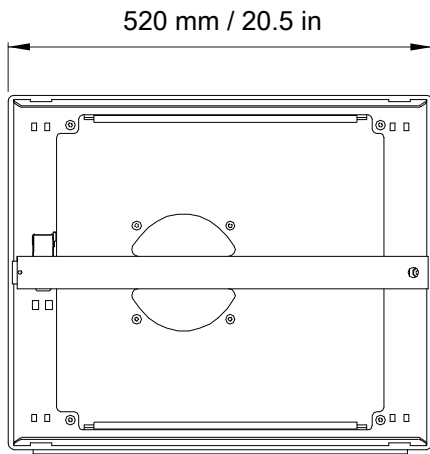

SB18 specifications

Description	High power compact subwoofer: 1 x 18" , amplified by LA4X / LA8 / LA12X
Low frequency limit (-10 dB)	32 Hz ([SB18_100])
Maximum SPL¹	138 dB ([SB18_100])
Directivity	standard or cardioid
Transducers	1 x 18"
Acoustical load	bass-reflex, L-Vents
Nominal impedance	8 Ω
Connectors	IN: 1 x 4-point speakON LINK: 1 x 4-point speakON
Rigging and handling	2 handles integrated into the cabinet captive rigging system 1 x 35 mm pole socket
Weight (net)	52 kg / 115 lb
Cabinet	first grade Baltic birch plywood
Front	steel grill with anti-corrosion coating acoustically neutral 3D fabric
Rigging components	steel with anti-corrosion coating
Finish	dark grey brown Pantone 426C
IP	IP45

¹ Peak level at 1 m under half space conditions using pink noise with crest factor 4 (preset specified in brackets).

SB18 dimensions

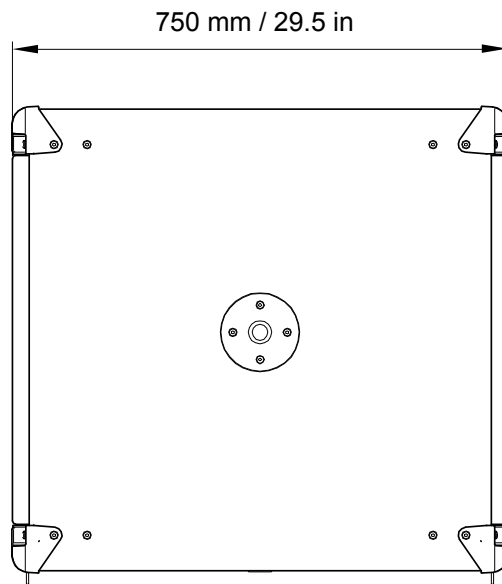
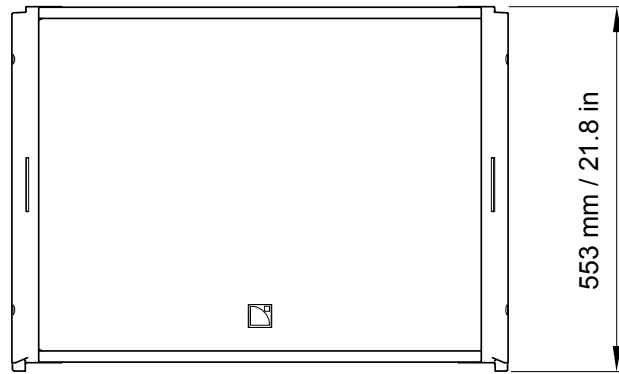
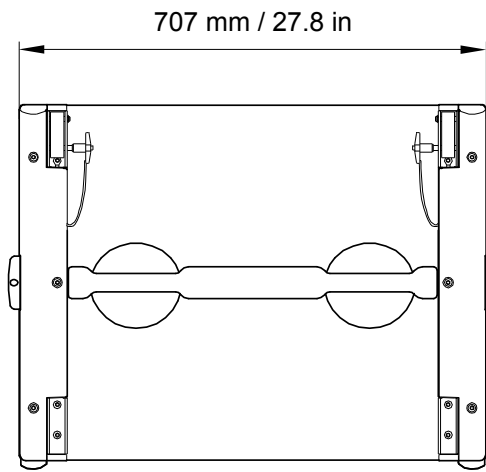



L-Acoustics, an L-Group Company

13 rue Levacher Cintrat - 91460 Marcoussis - France
+33 1 69 63 69 63 - info@l-acoustics.com
www.l-acoustics.com

L-Acoustics GmbH

Steiermärker Str. 3-5
70469 Stuttgart
Germany
+49 7 11 89660 323

L-Acoustics Ltd.

PO. Box Adler Shine - Aston House
Cornwall Avenue - London N3 1LF
United Kingdom
+44 7224 11 234

L-Acoustics Inc.

2645 Townsgate Road, Suite 600
Westlake Village, CA 91361
USA
+1 805 604 0577



L-GROUP

www.l-group.com